

**User Manual**  
For  
**DCM8028 and DCM8055**  
**High Performance Microstepping Driver**

Attention: Please read this manual carefully before using driver!



Haydon Switch & Instrument, Inc. (HSI)  
[www.hsi-inc.com](http://www.hsi-inc.com)  
203-756-7441 USA

Haydon Linear Motors (HLM)  
[www.hlm.com.cn](http://www.hlm.com.cn)  
86-519-5113312 5113316 China

Haydon Motion Europe (HME)  
[www.haydoneurope.com](http://www.haydoneurope.com)  
33-(0) 2 40 92 87 51

The content of this manual has been carefully prepared and is believed to be accurate, but no responsibility is assumed for inaccuracies.

Haydon does not assume any liability arising out of the application or use of any product or circuit described herein; neither does it convey any license under the patent rights of others. All third party liabilities are the responsibility of the customer. Haydon reserves the right to make changes without further notice to any products herein to improve reliability, performance, function or design.

All Rights Reserved

8-08

## Table of Contents

1. Introduction, Features and Applications .....	2
2. Specifications and Operating Environment .....	2
3. Driver Connectors P1 and P2 .....	3
4. Power Supply .....	4
5. Driver Voltage and Current .....	4
6. Selecting Microstep Resolution and Driver Current .....	5
7. Control Signal Connector (P1) Interface .....	6
8. Protection Features .....	8
9. Driver Connection to Motors .....	8
10. Connection Diagram for Driver, Motor, Controller .....	11
11. Control signal waveform and timing .....	11

### 1. Introduction, Features and Applications

DCM8055/DCM8028 is a high performance microstepping driver based on the most advanced technology in the world today. It is suitable for driving 2-phase hybrid step motors (current 5.5A/2.8A). By using advanced bipolar constant-current chopping technique, it can output more speed and power from the same motor, compared with traditional technologies such as L/R drivers. Its current control technology allows coil currents to be accurately controlled, with much less current ripple and motor heating than other drivers on the market.

#### Features of this driver

- High performance, low cost
- Supply voltage up to +80VDC\*, current to 5.5A for DCM8055; 2.8A for DCM8028.
- Inaudible 20khz chopping frequency
- TTL compatible and optically isolated input signals
- Automatic idle-current reduction
- Mixed-decay current control for less motor heating
- 14 selectable resolutions in decimal and binary
- Microstep resolutions up to 51,200 steps/rev
- Suitable for 4,6,8 lead motors
- Over-current, over-voltage and short-circuit protection
- Small size (115 x 97 x 48mm for DCM8055, 115 x 97 x 31mm for DCM8028)

#### Applications of this driver

Suitable for a wide range of stepping motors such as low voltage versions of sizes 11, 14, 17, 23 and 34, and usable for various kinds of machines, such as X-Y tables, labeling machines, laser cutters, engraving machines, and pick-place devices, particularly useful in applications with low noise, low vibration, high speed and high precision requirements.

### 2. Specifications and Operating Environment

#### Electric Specifications (T<sub>j</sub> = 25°C)

Parameters	DCM8055/DCM8028			
	Min	Typical	Max	Remark
RMS Output Current	2.0A,/1.0A	by user	5.5A,/2.8A	By DIP switch
Supply voltage (DC)	+20V	+68V	+80V *	
Logic signal current	10mA	12mA	18mA	
Pulse input frequency	0	By user	500Khz	
Isolation resistance	500MΩ			

**NEVER connect power and ground in the wrong polarity, it will damage the driver.  
NEVER connect or disconnect the motor leads with power on to the driver.**

\* For the European Market – the maximum input voltage must be limited to 70VDC to comply with CE regulations.

DCM8055/DCM8028 High Performance Microstepping Driver

**Operating Environment and Parameters**

Cooling	Natural cooling or forced convection	
Environment	Space	Avoid dust, oil, frost and corrosive gas
	Temperature	0° – 50°C
	Humidity	40 – 90%RH
	Vibration	5.9m/s <sup>2</sup> Max
Storage Temp.	-20°C – +65°C	
Weight	About 0.44kg/DCM8055; 0.33kg/DCM8028	

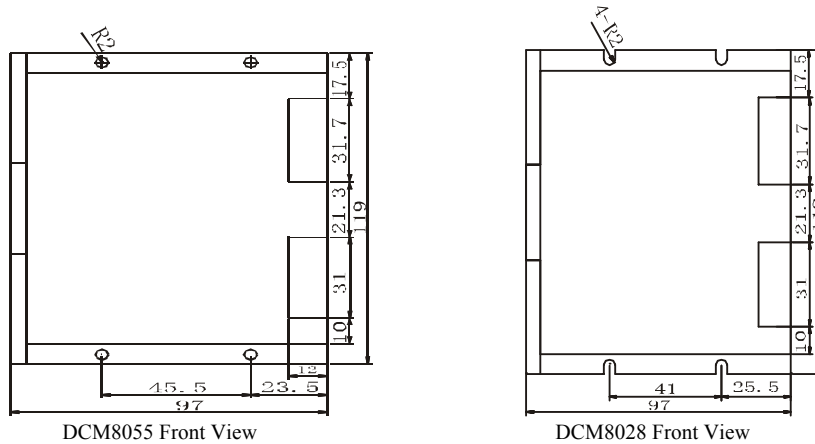

Figure 1: Mechanical Dimensions

### 3. Driver Connectors, P1 and P2

The following is a brief description of the two connectors of the driver. More detailed descriptions of the pins and related issues are presented in section 4, 6, 8, 9.

**Control Signal Connector P1-pins**

Pin No.	Signal	Functions
1	Pul + (+5V)	Pulse signal: in single pulse(pulse/direction) mode, this input represents pulse signal, effective for each upward – rising edge; in double pulse mode (pulse/pulse) this input represents clockwise(CW)pulse. For reliable response, pulse width should be longer than 3 $\mu$ s.
2	Pul - (pulse)	
3	Dir + (+5V)	Direction signal: in single-pulse mode, this signal has low/high voltage levels, representing two directions of motor rotation; in double-pulse mode (set by inside jumper JMPI), this signal is counter-clock (CCW) pulse, effective on each rising edge. For reliable motion response, direction signal should be sent to driver 2 $\mu$ s before the first pulse of a motion direction reversal.
4	Dir - (Dir)	
5	Ena+(+5V)	Enable signal: this signal is used for enable/disable, high level for enabling driver and low level for disabling driver. Usually left unconnected(enabled).
6	Ena- (Ena)	

\* For the European Market – the maximum input voltage must be limited to 70VDC to comply with CE regulations.

**Remark 1:** Pul/dir is the default mode, under-cover jumper JMP1 can be used to switch to CW/CCW double-pulse mode.

**Remark 2:** Please note motion direction is also related to motor-driver wiring match. Exchanging the connection of two wires for a coil to the driver will reverse motion direction. (for example, reconnecting motor A+ to driver A- and motor A- to driver A+ will invert motion direction).

#### Power connector P2 pins

Pin No.	Signal	Functions
1	Gnd	DC power ground
2	+V	DC power supply, +20VDC to +80VDC*, including voltage fluctuation and EMF voltage.
3, 4	Phase A	Motor coil A (leads A+ and A-)
5, 6	Phase B	Motor coil B (leads B+ and B-)

## 4. Power supply Selection

It is important to choose appropriate power supply to make the driver operate properly.

#### Maximum Voltage Input:

The power Mosfet inside the driver can actually operate within +20V to +80VDC\*, including power input fluctuation and back EMF voltage generated by motor coils during motor shaft deceleration. Higher voltage will damage the driver. Therefore, it is suggested to use power supplies with theoretical output voltage of no more than +75V, leaving room for power line fluctuation and Back EMF.

#### Regulated or Unregulated power supply:

Both regulated and unregulated power supplies can be used to supply DC power to the driver. However, unregulated power supplies are preferred due to their ability to withstand current surge. If a regulated power supply is used, it should be a linear type.

#### Multiple drivers:

It is possible to have multiple drivers share one power supply to reduce cost, provided that the supply has enough capacity. **DO NOT** daisy-chain the power supply input pins of the drivers(connect them to power supply separately) to avoid cross interference. Higher supply voltage will allow higher motor speed to be achieved, at the price of more noise and heating. If the motion speed requirement is low, it's better to use lower supply voltage to improve noise, heating and reliability. NEVER connect power and ground in the wrong polarity, it will damage the driver. NEVER connect or disconnect the motor leads with power on to the driver.

## 5. Driver Voltage and Current Selection

This driver can operate small-medium size step motors (such as low voltage versions of sizes 11, 14, 17, 23 and 34) made by Haydon or other motor manufactures from around the world. To achieve good driving results, it is important to select supply voltage and output current properly. Generally, supply voltage determines the high speed performance of the motor,

#### ● Selecting Supply Voltage:

Higher supply voltage can increase motor torque at higher speeds, thus helpful for avoiding losing steps. However, higher voltage may cause more motor vibration at lower speed, and it may also cause over-voltage protection and even driver damage. Therefore, it is suggested to choose only sufficiently high supply voltage for intended applications.

\* For the European Market – the maximum input voltage must be limited to 70VDC to comply with CE regulations.

### ● Setting Proper Output Current

For a given motor, higher driver current will make the motor output more torque, but at the same time causes more heating in the motor and driver. Therefore, output current is generally set to be such that the motor will not overheat for long time operation. Since parallel and serial connections of motor coils will significantly change resulting inductance and resistance, it is therefore important to set driver output current depending on motor phase current, motor leads and connection methods. Phase current rating supplied by motor manufacturer is important to selecting driver current, but the selection also depends on leads and connection:

## 6. Selecting Microstep Resolution and Driver Current Output

This driver uses an 8-bit DIP switch to set microstep resolution, dynamic current and standstill current, as shown below:

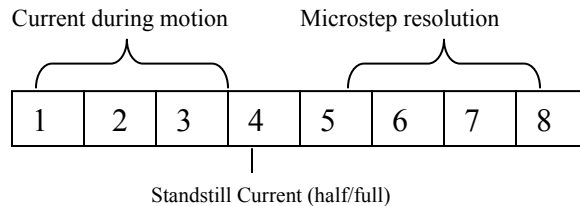

### ● Microstep Resolution Selection

Microstep resolution is set by SW5, 6, 7, 8 of the DIP switch as shown in the following table:

Microstep	Step/rev.(for 1.8° motor)	SW5	SW6	SW7	SW8
2	400	on	on	on	on
4	800	on	off	on	on
8	1600	on	on	off	on
16	3200	on	off	off	on
32	6400	on	on	on	off
64	12800	on	off	on	off
128	25600	on	on	off	off
256	51200	on	off	off	off
5	1000	off	on	on	on
10	2000	off	off	on	on
25	5000	off	on	off	on
50	10000	off	off	off	on
125	25000	off	on	on	off
250	50000	off	off	on	off

### ● Current Setting

The first three bits (SW1, 2, 3) of the DIP switch are used to set the current during motion (dynamic current), while SW4 is used to select standstill current. **NOTE: Current settings below are per phase.**

#### DCM8028/DCM8055 DIP Switch settings for RMS current during motion:

Current for DCM8028	Current for DCM8055	SW1	SW2	SW3
1.0A	2.0A	on	on	on
1.3A	2.5A	off	on	on
1.5A	3.0A	on	off	on
1.8A	3.5A	off	off	on
2.0A	4.0A	on	on	off
2.3A	4.5A	off	on	off
2.5A	5.0A	on	off	off
2.8A	5.5A	off	off	off

\* For the European Market – the maximum input voltage must be limited to 70VDC to comply with CE regulations.

Note that due to motor inductance the actual current in the coil may be smaller than the dynamic current settings, particularly at higher speeds.

**DIP setting for current during standstill:**

SW4 is used for this purpose, the half current setting will reduce motor heating at standstill. OFF meaning that the standstill current is set to be half of the dynamic current and ON meaning that standstill current is set to be the same as dynamic current.

## 7. Control Signal Connector (P1) Interface

This driver uses differential inputs to increase noise immunity and interface flexibility. Single-ended control signals from the indexer/controller can also be accepted by this interface. The input circuit has built-in high-speed opto-coupler, and can accept signals in the format of line driver, open-collector, or PNP output. Line driver (differential) signals are suggested for reliability. In the following figures, connections to open-collector and PNP signals are illustrated and  $VCC = 5VDC$ . For other  $VCC$  voltages limit the current to 18mA maximum.

Examples:  $R=560\Omega$  if  $VCC=12VDC$   
 $R=1.5K\Omega$  if  $VCC=24VDC$

Open-collector signal (common +)

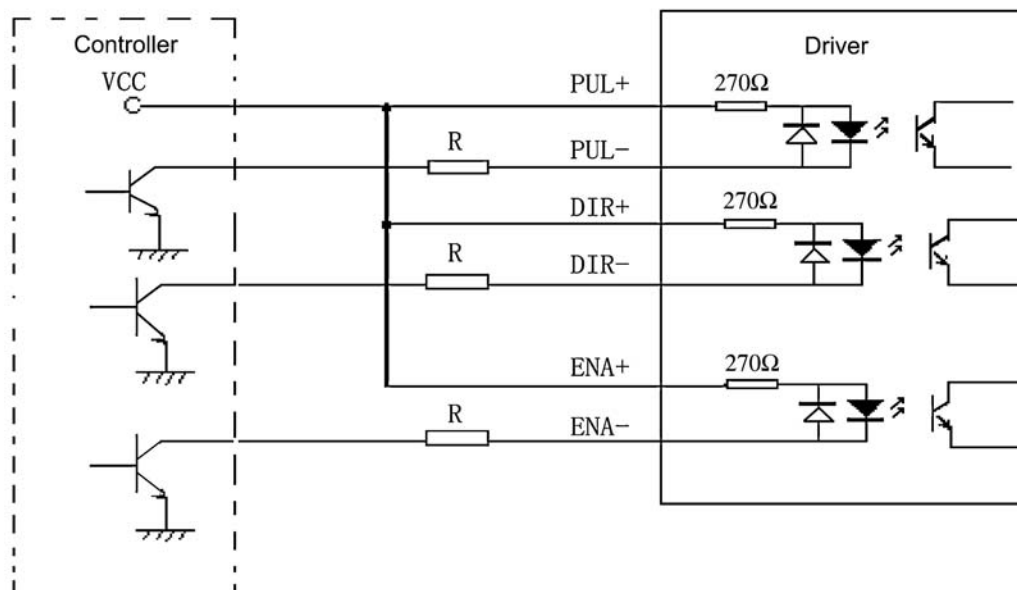

Figure 2

\* For the European Market – the maximum input voltage must be limited to 70VDC to comply with CE regulations.

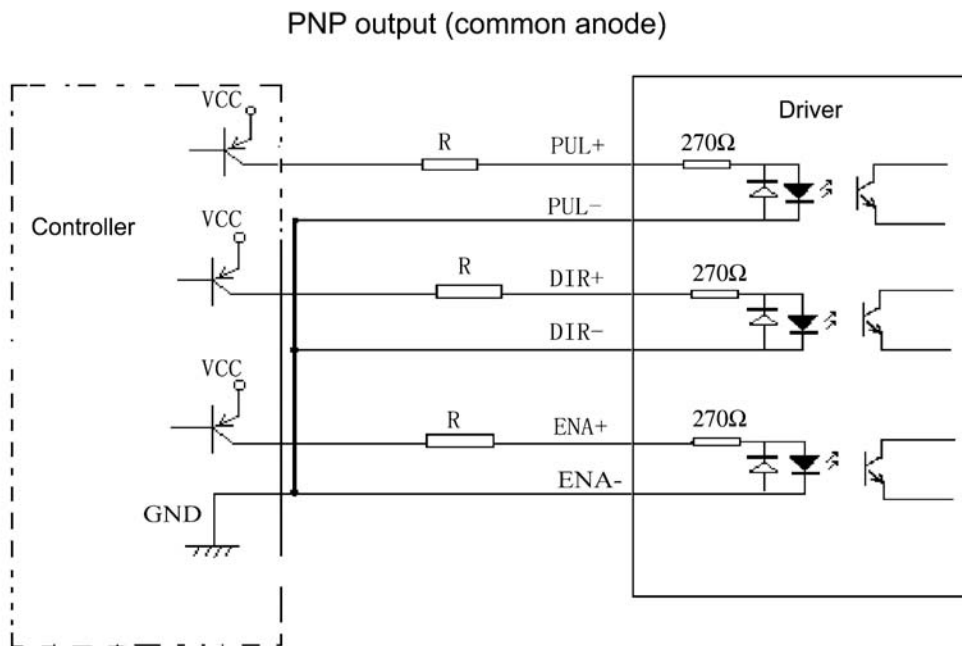
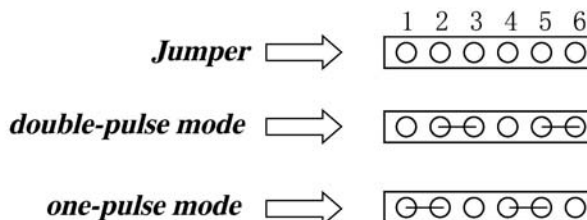

Figure 3: Signal Interface

**Single Pulse and Double Pulse Modes**

There is a jumper JM<sub>pi</sub> inside the driver specifically for the purpose of selecting pulse signal mode, settings for one-pulse mode(pulse/dir)and for double-pulse mode(CW/CCW)are shown on the left. Default mode out of factory is one pulse Mode.



\* For the European Market – the maximum input voltage must be limited to 70VDC to comply with CE regulations.

## 8. Protection Functions

To improve reliability, the driver incorporates a number of built-in protection features.

### a. Over-voltage protection

When power supply voltage exceeds +80VDC\*, protection will be activated and power indicator LED will turn red. When power supply voltage is lower than +20VDC, the driver will not work properly.

### b. Coil-ground Short Circuit Protection

Protection will be activated in case of short circuit between motor coil and ground.

### c. Over-current Protection

Protection will be activated in case of excessive current (such as a short circuit) which may otherwise damage the driver.

**Attention:** since there is no protection against power leads ( + , - ) reversal, it is critical to make sure that power supply leads are correctly connected to driver. Otherwise, the driver will be damaged instantly.

## 9. Driver Connection to Step Motors

DCM8055/DCM8028 driver can drive 4, 6, 8 lead hybrid step motors. The following diagrams illustrate connection to various kinds of motor leads:

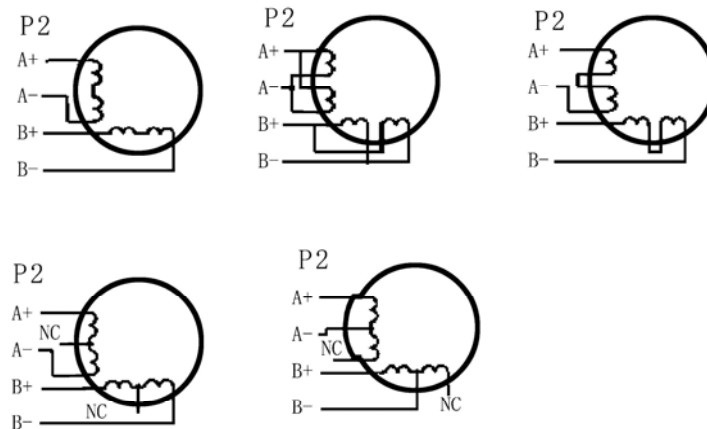

Figure 4: Driver Connection to Step Motor

Note that when two coils are parallelly connected, coil inductance is reduced by half and motor speed can be significantly increased. Serial connection will lead to increased inductance and thus the motor can be run well only at lower speeds.

### 9.1 Connecting to 8-Lead Motors

8 lead motors offer a high degree of flexibility to the system designer in that they may be connected in series or parallel, thus satisfying a wide range of applications.

#### Series Connection

A series motor configuration would typically be used in applications where a higher torque at lower speeds is required. Because this configuration has the most inductance, the performance will start to degrade at higher speeds. Divide the motor's unipolar (peak) current rating by 1.4 for the RMS current, or the motor's bipolar current rating is the RMS current.

\* For the European Market – the maximum input voltage must be limited to 70VDC to comply with CE regulations.

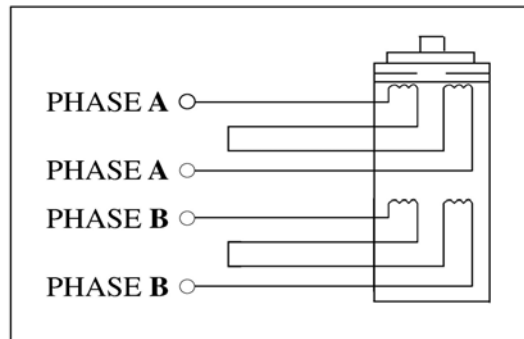

Figure 5: 8 Lead Motor Series Connections

**Parallel Connection**

An 8 lead motor in a parallel configuration, because of the lower inductance, will have higher torque at higher speeds. Multiply the motor's unipolar (peak) current rating by 1.4 for the RMS current, or the motor's bipolar current rating is the RMS current.

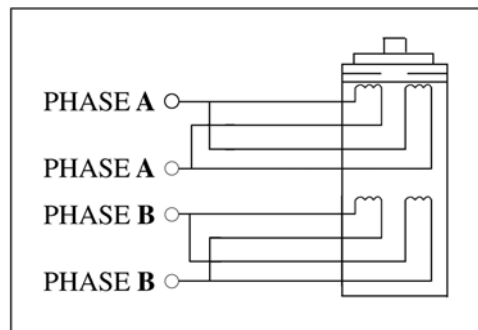

Figure 6: 8 Lead Motor Parallel Connections

**9.2 Connection to 6-Lead Motors**

Like 8 lead stepping motors, 6 lead motors have two configurations available for high speed or high torque operation. The higher speed configuration, or half coil, is so described because it uses one half of the motor's inductor windings. The higher torque configuration, or full coil, use the full windings of the phases.

**Half Coil Configuration**

As previously stated, the half coil configuration uses 50% of the motor phase windings, hence, lower torque output. Like the parallel connection of 8 lead motor, the torque output will be greater at higher speeds due to lower inductance. This configuration is also referred to as half copper. In setting the driver output current use the motor's specified per phase (or unipolar) current rating as the RMS current.

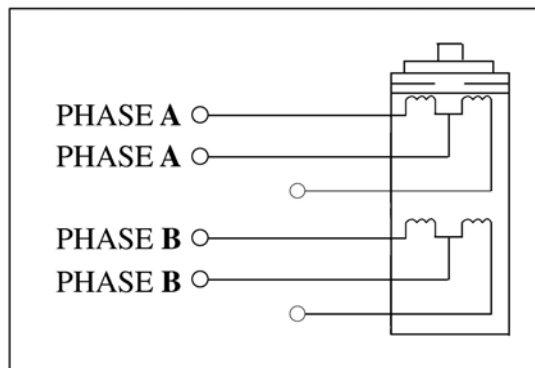

Figure 7: 6 Lead Half Coil (Higher Speed) Motor Connections

**Full Coil Configuration**

The full coil configuration on a six lead motor should be used in applications where higher torque at lower speeds is desired. This configuration is also referred to as full copper. Divide the motor's specified per phase (or unipolar) current rating by 1.4 for the RMS current.

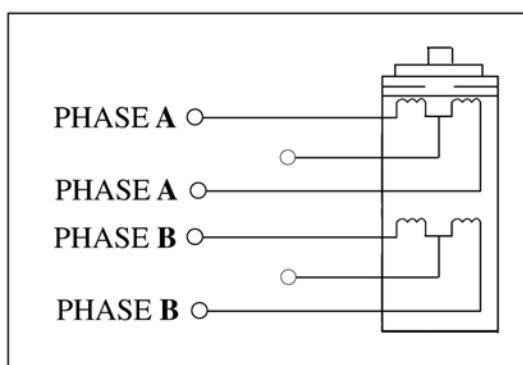

Figure 8: 6 Lead Full Coil (Higher Torque) Motor

**9.3 Connection to 4-Lead Motors**

4 lead motors are the least flexible but easiest to wire. Speed and torque will depend on winding inductance. In setting the driver output current, use the motors specified per phase current rating as the RMS current.

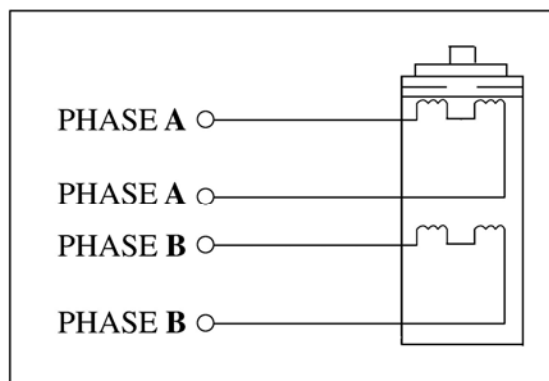

Figure 9: 4 Lead Motor Connections

\* For the European Market – the maximum input voltage must be limited to 70VDC to comply with CE regulations.

## 10. Connection Diagram for Driver, Motor, Controller

A complete stepping system should include stepping motor, stepping driver, power supply and controller (pulse generator).

A typical connection is shown below:

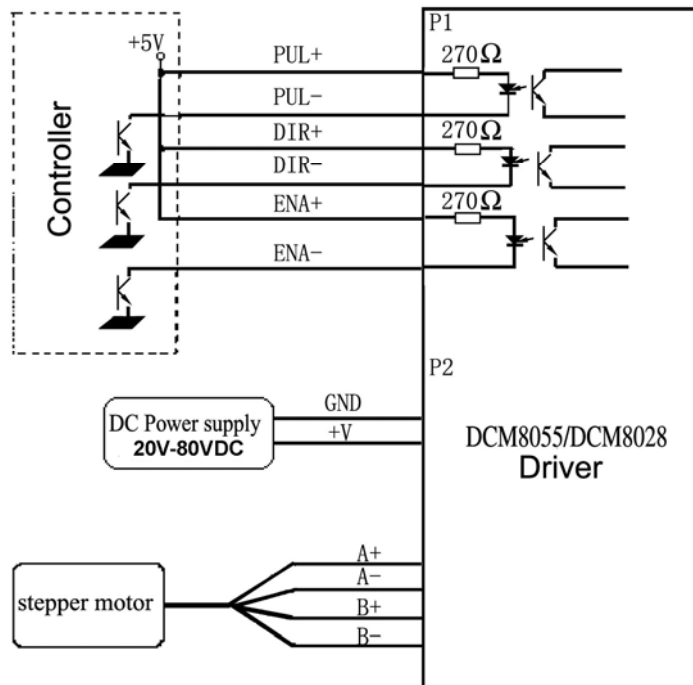
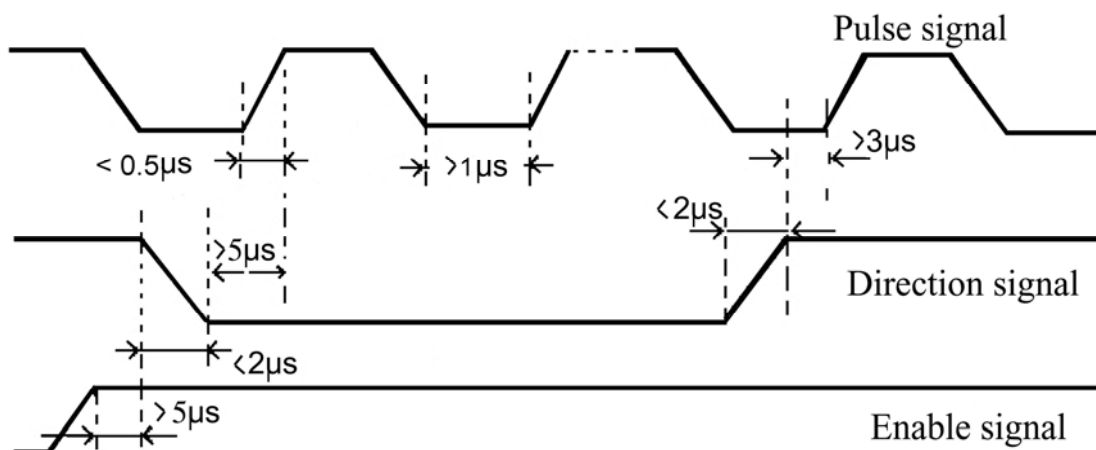

Figure 10: Driver connection in a stepping system

## 11. Control signal Waveform and Timing



This driver can accept pulse control signals up to 500KHz. Before a direction reversal, direction signal needs to be established at least 3  $\mu\text{s}$  before the first pulse of the next pulse train. Please examine time diagrams of the three control signals as follows.

\* For the European Market – the maximum input voltage must be limited to 70VDC to comply with CE regulations.